

DOOR PLUS

- Unleash Elegance: Where Doors Speak Style -



Where **Style** Meets **Security**



www.doorplusme.com



AUTOMATIC SWING DOORS

DOOR PLUS

1. DP80 Extreme Drive - Swing Door

- A : Short Description - pg - 2
- B : Key Pros and Merits - pg -3
- C : Areas of use - pg - 3
- D : Product Description - pg- 4

2. DP100 Slim Drive - Swing Door

- A : Short Description - pg -7
- B : Key Pros and Merits - pg -8
- C : Areas of use - pg - 8
- D : Product Description - pg- 9

3. DP200 Intensive Drive - Swing Door

- A : Short Description - pg -11
- B : Key Pros and Merits - pg -12
- C : Areas of use - pg - 12
- D : Product Description - pg- 13

4. DP350 Heavy Duty - Swing Door

- A : Short Description - pg -15
- B : Key Pros and Merits - pg -16
- C : Areas of use - pg - 16
- D : Product Description - pg- 17

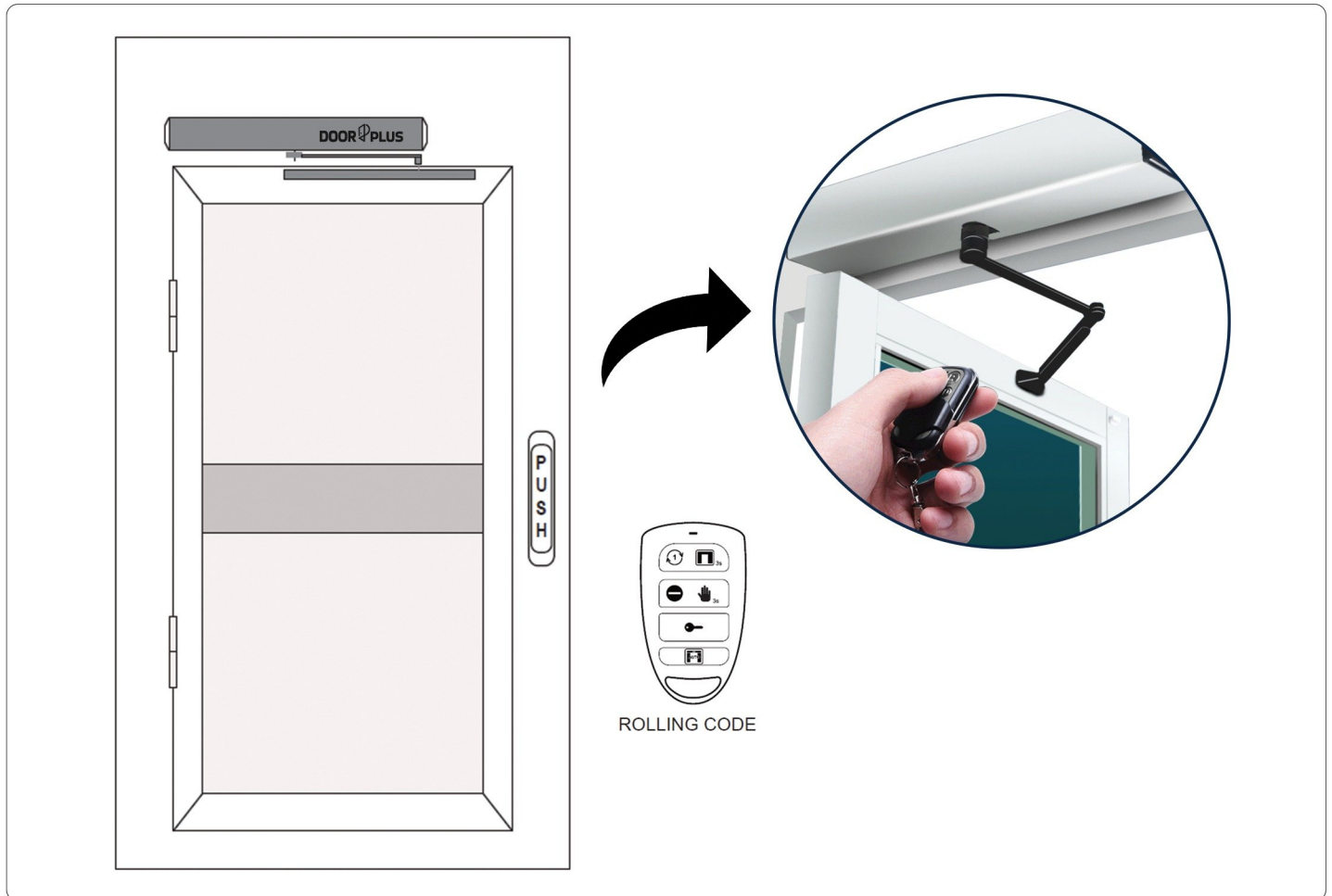

DP80 EXTREME DRIVE | AUTOMATIC SWING DOOR

DP80 Swing Door: Proven Elegance, EN16005 Approved

1 SWING DOOR INNOVATIONS

1.1 Short Description

Introducing our advanced automatic swing door system, designed for a seamless and reliable entrance experience. Equipped with an auto-reverse function for enhanced safety in both closing and opening directions, this system features a worm and worm gear decelerator ensuring super-silent operation, minimal abrasion, and extended durability. Offering versatility with sliding arm and articulated arm options, the door can open inside or outside. Various opening modes, including remote control, card reader, motion sensor, and opening button, provide convenient access. With proven reliability through over 2 million cycles of durability tests, this system is a silent powerhouse. Interfaces are available for connecting fire alarm signals, backup batteries, and electric locks, while digital parameter adjustments add flexibility. Suited for diverse environments, from hospitals and office buildings to hotels and spaces catering to the elderly and disabled, our automatic swing door system represents cutting-edge technology for modern entrances.

1.2 Key Pros and Merits

Discover the unmatched advantages of our automatic swing door system—silent operation, enhanced safety, versatile configurations, and digital adjustability. Elevate entrances with enduring reliability and user-friendly access options.

- Enhanced Safety
- Extended Lifespan
- Convenient Access Options
- Flexibility for Parameter Adjustments
- Energy-Efficient Design
- Silent Operation
- Versatile Configuration
- Exceptional Reliability
- Integration Capabilities
- Wide Application Range

1.3 Areas of use

Our automatic swing door system is versatile, ideal for hospitals, offices, hotels, residences, retail, education, public transportation hubs, government buildings, industrial facilities, and entertainment venues, ensuring seamless and sophisticated entrances in diverse environments.

- Hospitals and Healthcare Facilities
- Office Buildings
- Hotels and Hospitality
- Residential Complexes
- Retail Stores and Showrooms
- Educational Institutions
- Public Transportation Hubs
- Government and Public Buildings
- Industrial Facilities
- Entertainment Venues

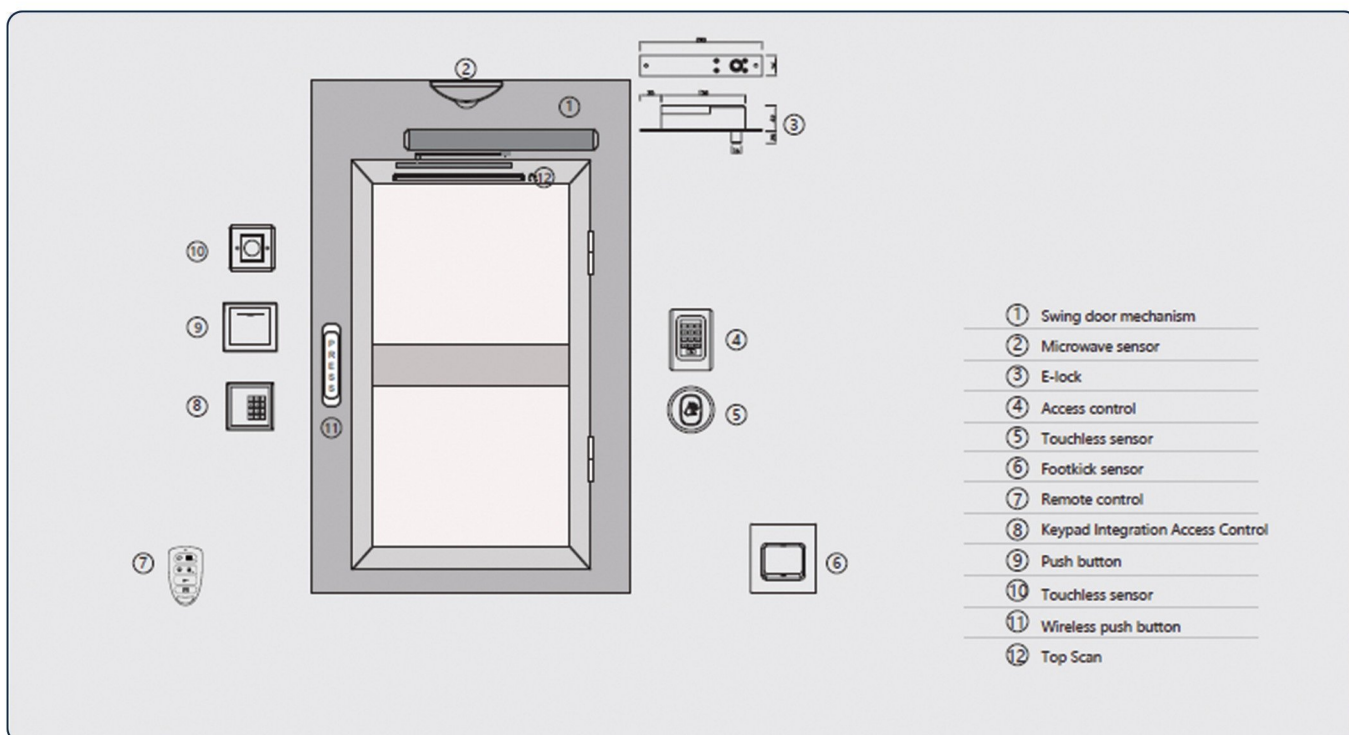

2 PRODUCT

2.1 Product Description

Introducing our cutting-edge Automatic Swing Door System, a seamless blend of innovation and functionality. This system boasts an array of features, including an auto-reverse function for enhanced safety, a super-silent worm and worm gear decelerator for smooth operation, and dual configurations with sliding and articulated arms for versatile installations.

With various opening modes—remote control, card reader, motion sensor, and opening button—access becomes convenient and user-friendly. The system's exceptional reliability is demonstrated through rigorous durability tests, surpassing 2 million cycles.

Designed with flexibility in mind, digital parameter adjustments, and interfaces for fire alarm signals, backup batteries, and electric locks offer customization and integration capabilities. From hospitals to industrial facilities, our Automatic Swing Door System caters to diverse environments, providing a silent, reliable, and stylish solution for modern entrances. Elevate your space with the future of automated entry.



2.1.1 DP80 Extreme Drive

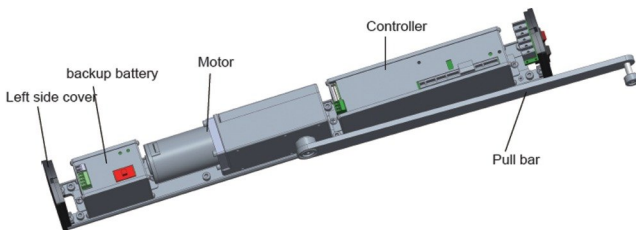

2.1.2 DP80 Components

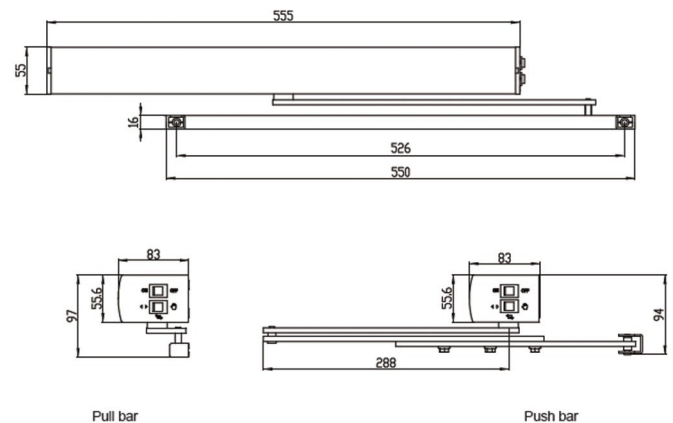

2.1.3 DP80 Swing door mechanism

2.2 Microwave sensor

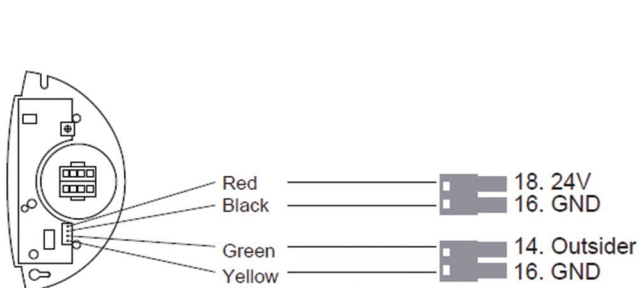

2.3 Footkick switch

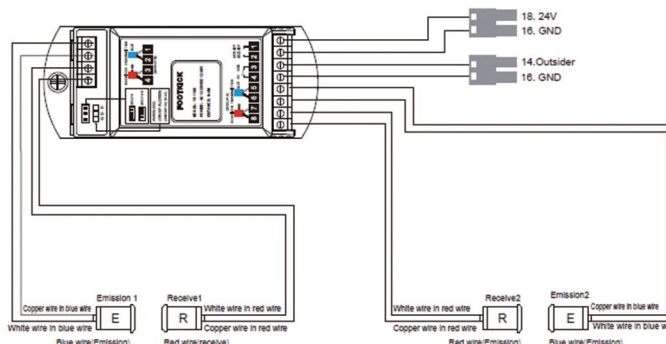

2.4 Photocell

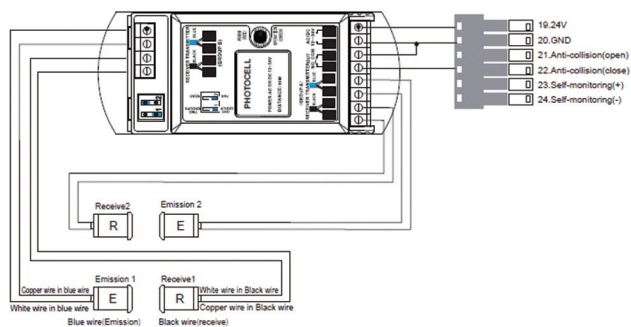

2.5 Wired Diagram

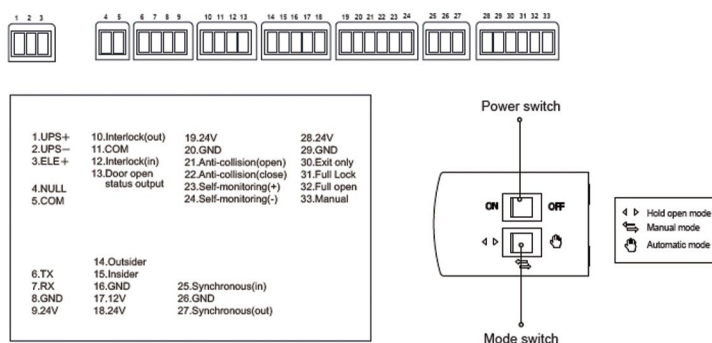

2.6 DP80 web(Function selector)

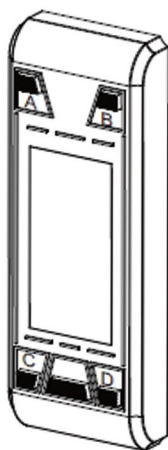

- Mode : Press and hold "MODE" for 8 seconds to enter the parameter adjustment mode, and press again for 8 seconds to return.
- A : Upward select technical code when working as function selector / password setting meaning number 4
 - B : Upward select technical value when working as function selector / password setting meaning number 3
 - C : Downward select technical value when working as function selector / password setting meaning number 1
 - D : Downward select technical code when working as function selector / password setting meaning number 2

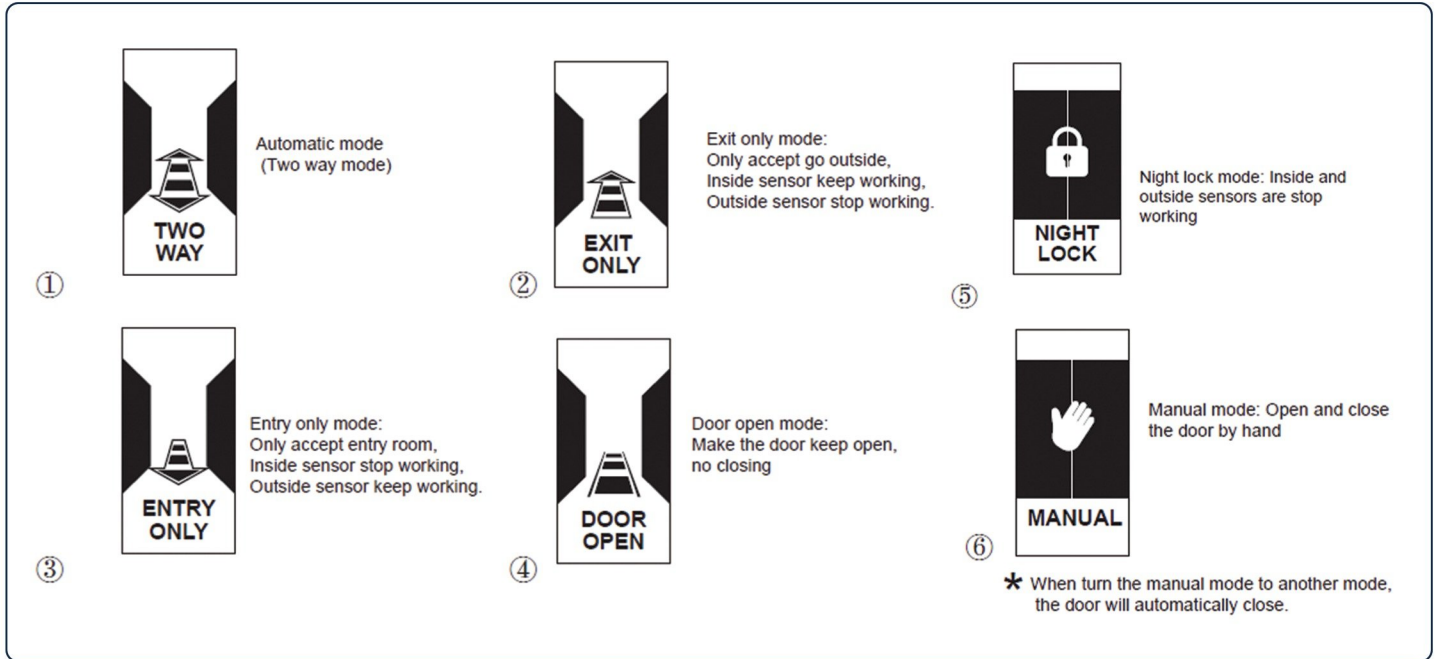

2.7 DP80 web(data adjuster)

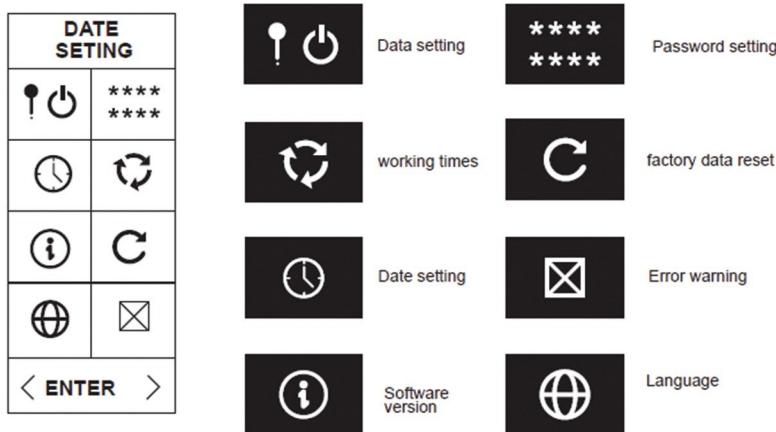

2.8 Opening side (OPTEx OA-EDGE T Master)

2.9 Closing side (OPTEx OA-EDGE T Master)

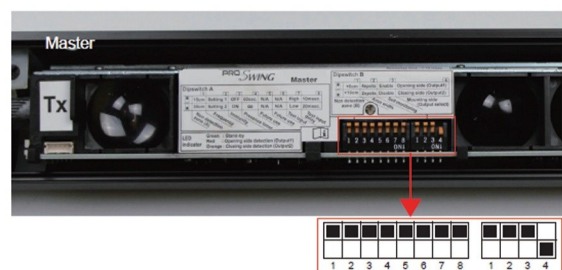
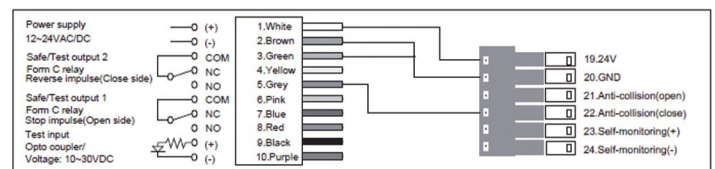
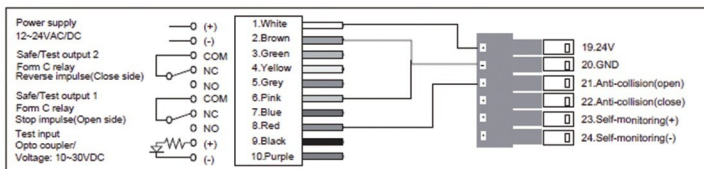

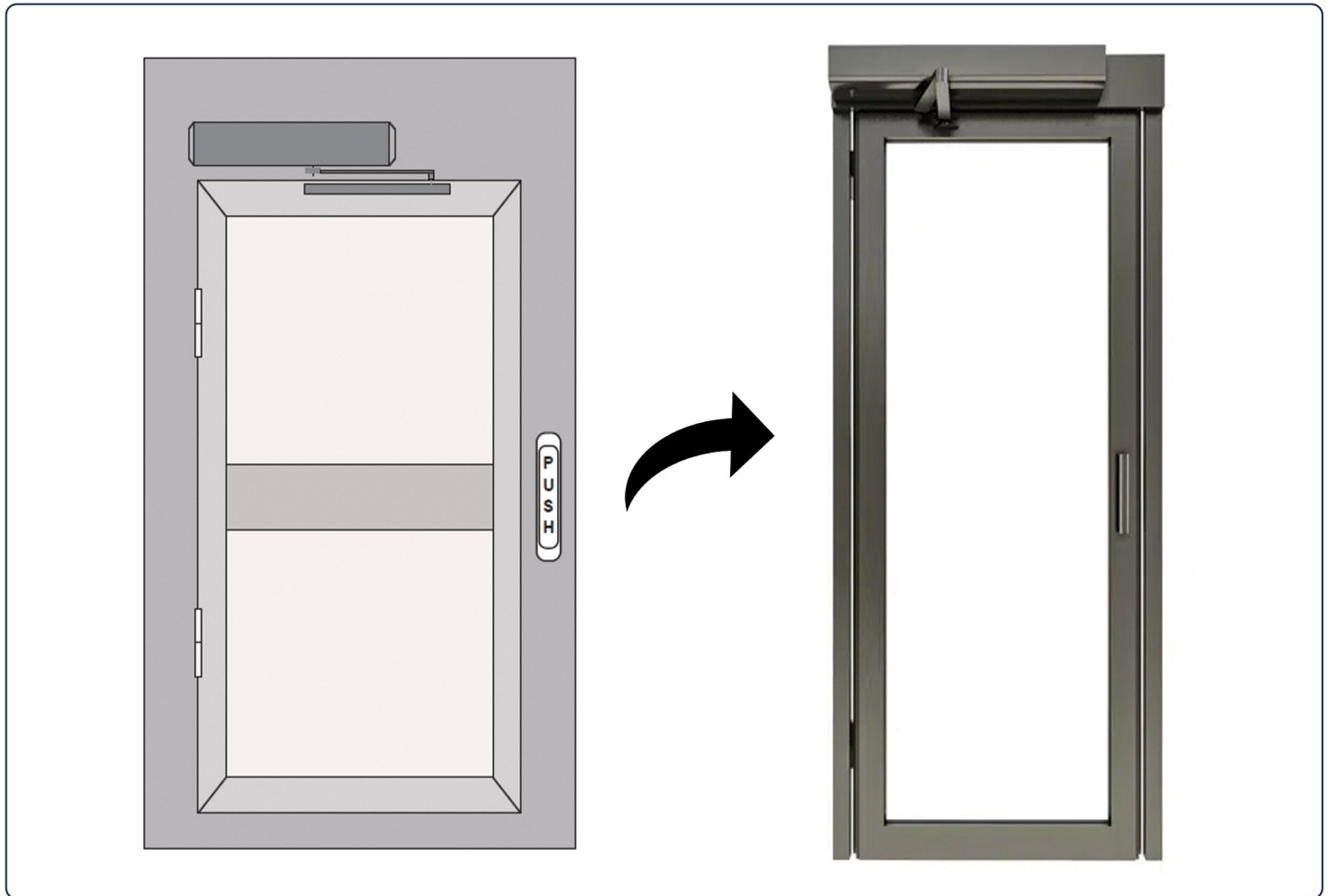

DP100 SLIM DRIVE | AUTOMATIC SWING DOOR

Sleek Access: DP100 Slim Drive, EN16005 Approved

1 REVOLUTIONIZING SWING DOOR TECHNOLOGY

1.1 Short Description

Introducing the DP100 Slim Drive, a pinnacle of excellence in automatic swing door operators, redefining access with a maximum bearing load of 100kgs. This 90-degree swing door operator seamlessly blends deluxe aesthetics and advanced encoding technology, ensuring a visually pleasing and sophisticated entrance experience. Beyond conventional models, the DP100 excels in smooth and stable operation, featuring microcomputer technology for push-and-open functionality and a modular design for easy installation. Safety is paramount with an intelligent self-protection mechanism against overheating and overload, along with automatic reversal upon obstruction. Versatile connectivity integrates with various access control devices, including remote control, password reader, card reader, and more, making it adaptable to diverse environments. With safety beam features, an optional backup battery, and a 24VDC 100W brushless motor, the DP100 promises reliable, silent performance. Elevate your entrance with the DP100 Slim Drive – where intelligence meets reliability in the era of automated access.

1.2 Key Pros and Merits

DP100 redefines swing door tech with a modular design, intelligent safety features, and advanced connectivity. A sleek and reliable choice for modern access solutions, combining innovation and sophistication.

- Advanced Encoding Technology
- Modular Design for Easy Maintenance
- Intelligent Self-Protection Mechanism
- Electromagnetic Lock Control
- Adjustable Parameters for Customization
- Advanced Brushless Motor
- Versatile Connectivity Options
- Safety Beam Feature
- Optional Backup Battery
- Efficient Motor Transmission

1.3 Areas of use

The DP100 sets a new standard in swing door technology, boasting a sleek design, intelligent safety features, and versatile connectivity. Elevate entrances with this innovative and sophisticated access solution.

- Hospitals and Healthcare Facilities
- Office Buildings
- Hotels and Hospitality
- Residential Complexes
- Retail Stores and Showrooms
- Educational Institutions
- Public Transportation Hubs
- Government and Public Buildings
- Industrial Facilities
- Entertainment Venues

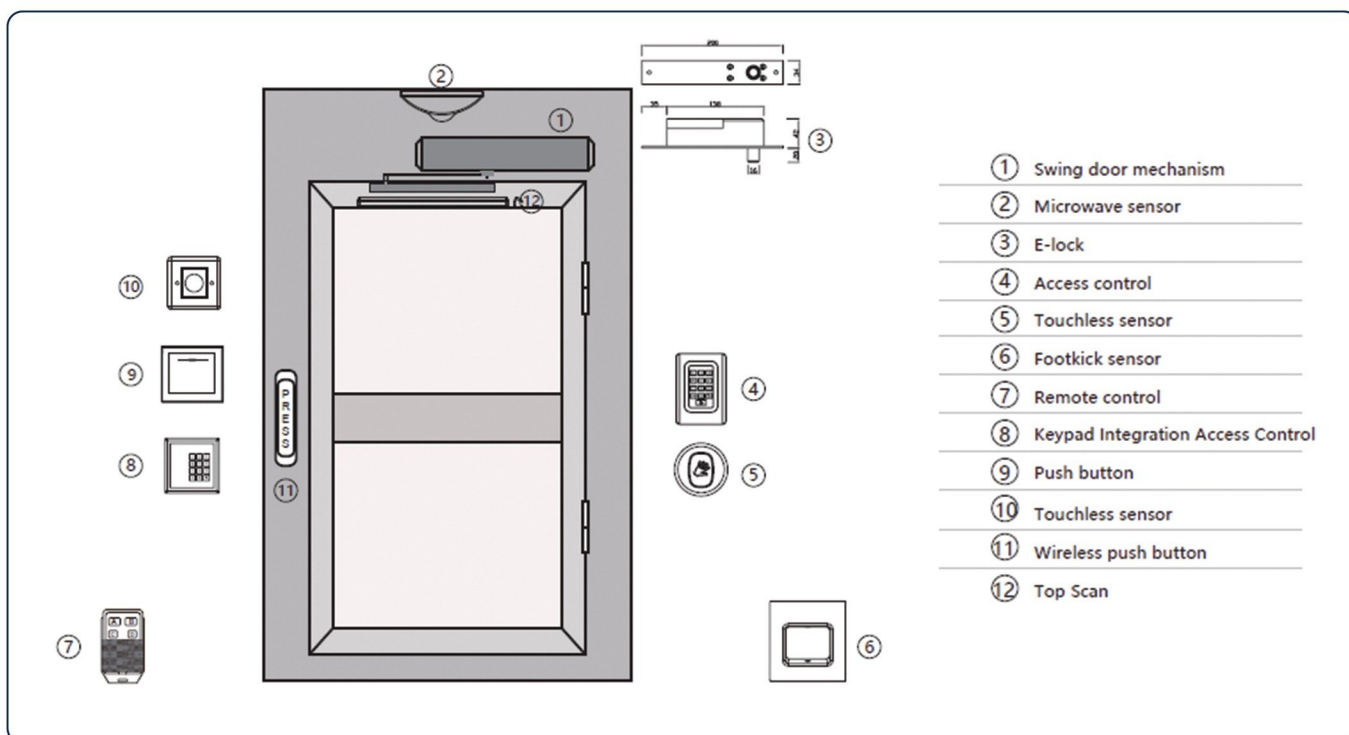

2 PRODUCT

2.1 Product Description

Introducing the DP100 Slim Drive, a cutting-edge automatic swing door operator redefining access with its blend of innovation, style, and functionality. Engineered for precision with a maximum bearing load of 100kgs, this 90-degree swing door operator is versatile and suitable for various environments.

The system offers electromagnetic lock control for added security and adjustable parameters for tailored operation. Its advanced brushless motor ensures energy efficiency, low noise, and extended service life. Versatile integration options for various access control devices, safety beam feature, and optional backup battery make DP100 a reliable choice for seamless entrances, promising super-silent performance and flexibility for diverse applications. Elevate your entrance experience with DP100 Slim Drive, where intelligence meets reliability for a new era of automated access solutions.

At the core of DP100 lies advanced encoding technology, ensuring precise and reliable door operations. Its modular design facilitates easy installation and low maintenance, providing an efficient solution for modern entrances. With an intelligent self-protection mechanism, DP100 automatically reverses upon obstruction during opening and closing, prioritizing user safety and enhancing building security.

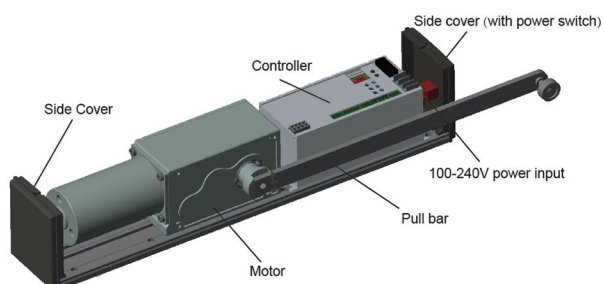

2.1.2 DP100 Components

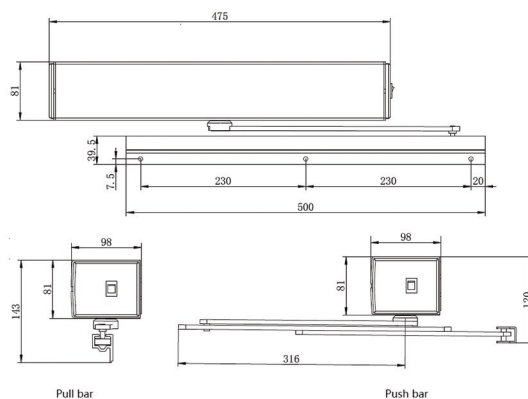

2.1.3 DP100 Swing door mechanism

2.2 Microwave sensor

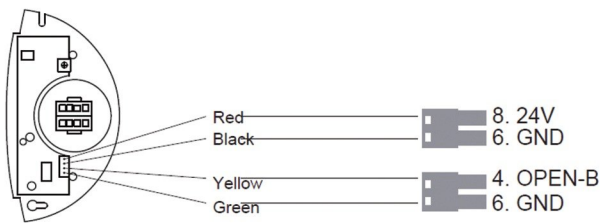

2.3 Footkick sensor

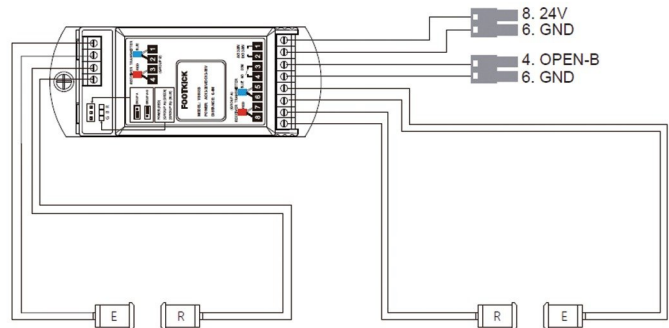

2.4 Photocell

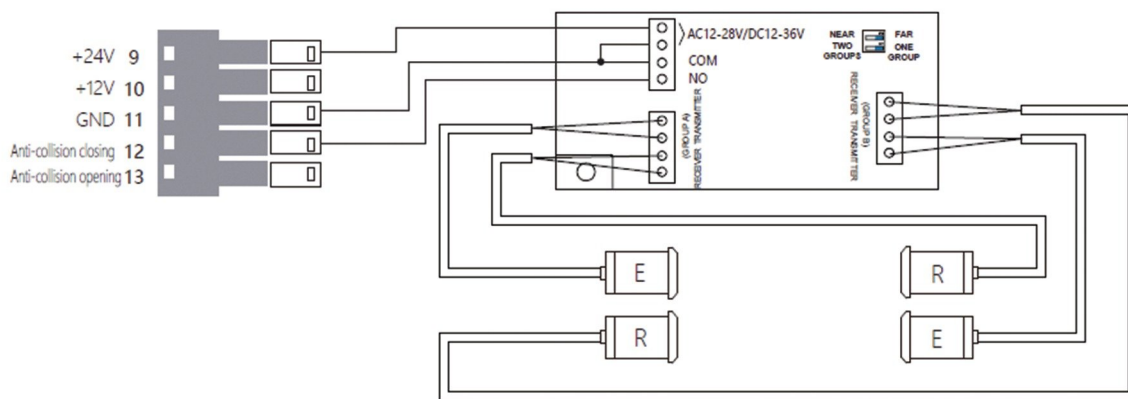

2.5 Function of remote

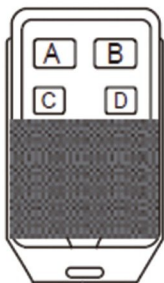

- A : Always open
- B : Automatic
- C : Open one time
- D : Full lock

2.6 Data setting

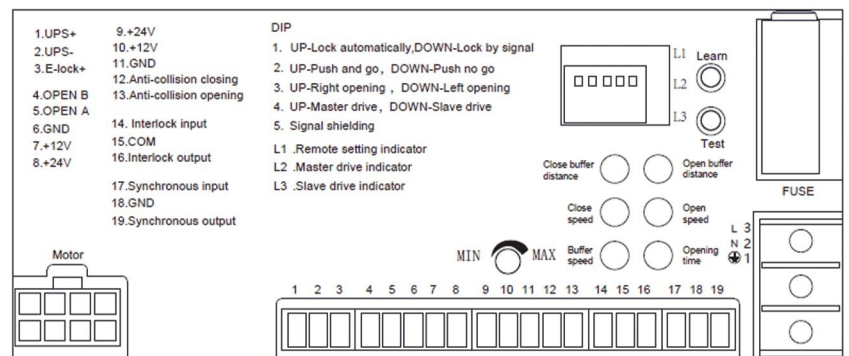



DP200 INTENSIVE DRIVE | AUTOMATIC SWING DOOR

DP200 : Timeless Elegance, EN16005 Certified Excellence

1 TRANSFORMING SWING DOOR INNOVATION

1.1 Short Description

The DP200 Swing Door presents a revolution in accessibility technology with its wide input voltage range of 100-240V, ensuring adaptability to diverse power sources. Designed with wind resistance of 3 grades, it ensures stability in various weather conditions. The adjustable door opening angle provides customization for different preferences. Combining the controller and transformer for space efficiency, this innovative system offers seamless sensor connections inside and outside without interference. Specifically designed for double open configurations, the DP200 boasts a specialized combined rail and cover, making it suitable for various door structures. Its high-performance, portable, and compact design ensures easy installation on different door types, promising efficiency and reliability.

1.2 Key Pros and Merits

The DP200 Swing Door excels with features like wide input voltage adaptability, grade 3 wind resistance, adjustable opening angles, and a combined controller and transformer, ensuring efficient, customizable, and versatile door solutions.

- Wide Input Voltage Range (100-240V)
- Wind Resistance (Grade 3)
- Adjustable Door Opening Angle
- Controller & Transformer Combined
- Non-Interference Sensor Connection
- Specialized Combined Rail and Cover
- High Performance
- Portability and Compact Design
- Suited for Various Door Structures
- Simple Mechanism for Easy Installation

1.3 Areas of use

The DP200 Swing Door offers versatile entrance solutions with advanced features, including wide input voltage adaptability, grade 3 wind resistance, and adjustable door opening, ensuring reliability in various settings and the area's of use are follows:

- Hospitals and Healthcare Facilities
- Office Buildings
- Hotels and Hospitality
- Residential Complexes
- Retail Stores and Showrooms
- Educational Institutions
- Public Transportation Hubs
- Government and Public Buildings
- Industrial Facilities
- Entertainment Venues

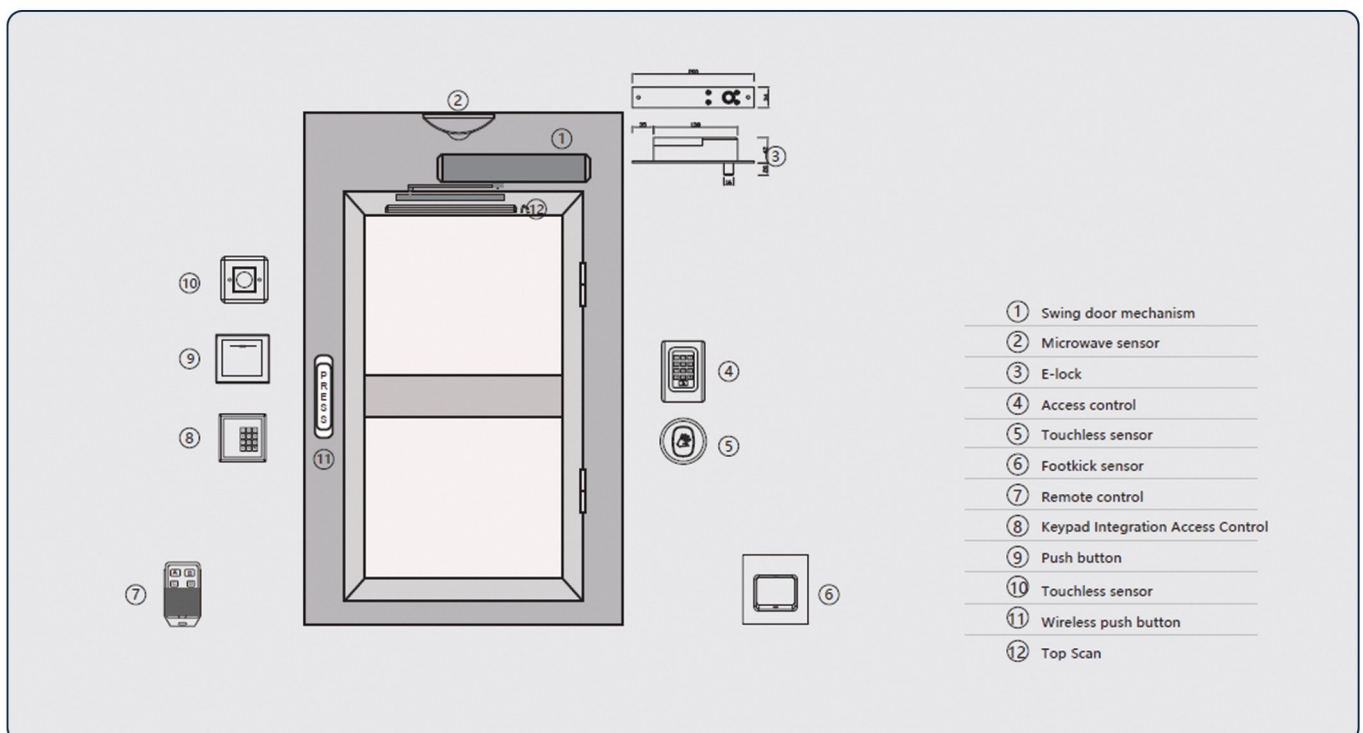

2 PRODUCT

2.1 Product Description

The DP200 Swing Door revolutionizes entrances with its cutting-edge features, setting a new standard for automated access technology. Its wide input voltage range, spanning from 100V to 240V, ensures adaptability to diverse power sources, promoting seamless integration into various environments. This swing door excels in stability, boasting grade 3 wind resistance to withstand challenging weather conditions. The ability to adjust the door opening angle caters to individual preferences, offering a customizable and user-friendly experience.

In terms of design, the DP200 stands out with its combination of controller and transformer, creating a space-efficient solution without compromising operational efficiency. The non-interference sensor connections inside and outside, along with a specialized rail and cover for double open configurations, showcase its versatility. Installation is simplified, making the DP200 an ideal choice for those seeking high performance, portability, and reliability in automated entrance solutions.

Whether deployed in commercial spaces, residential buildings, healthcare facilities, or educational institutions, the DP200 Swing Door promises secure, customizable, and efficient access experiences, marking a significant leap forward in the realm of modern entrance technology.

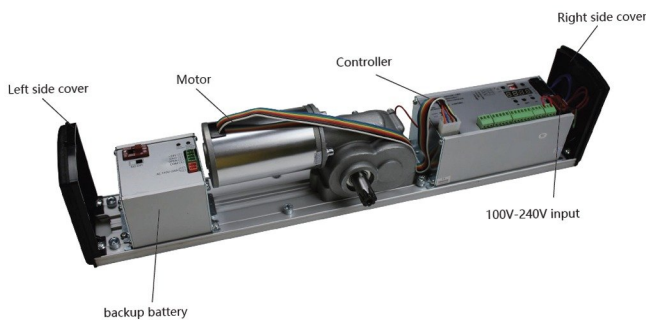

2.1.2 DP200 Components

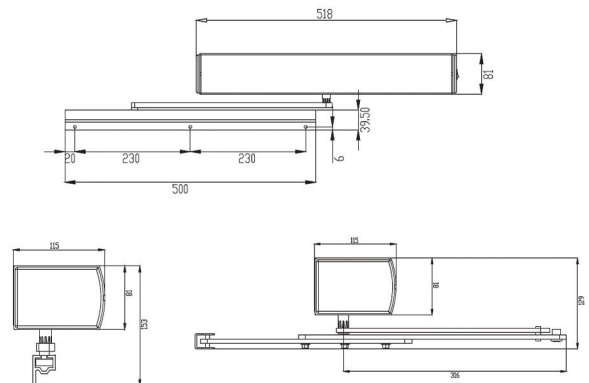

2.1.3 DP200 Swing door mechanism

2.2 Microwave sensor

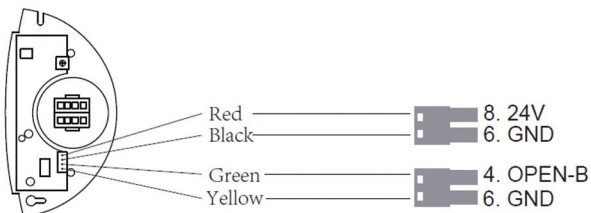

2.3 Footkick sensor

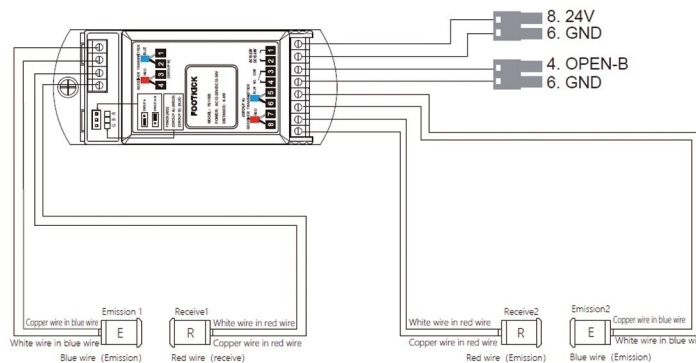

2.4 Photocell

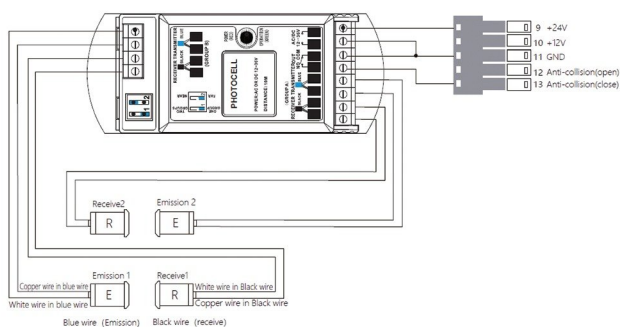

2.4 Wired Diagram (Terminal details)

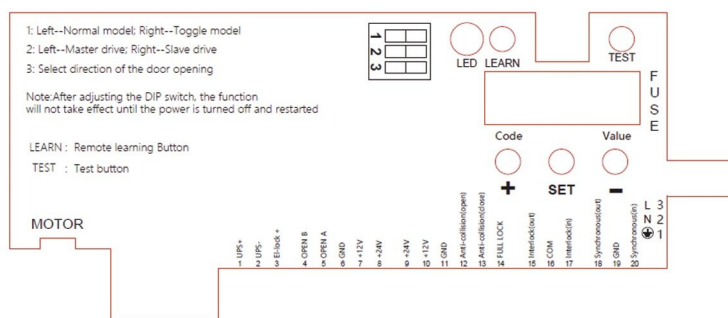

2.5 Function of remote

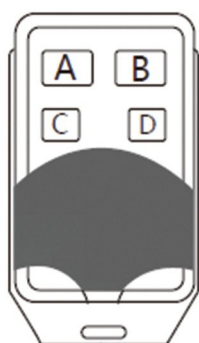

- A: Always open
- B: Automatic
- C: Open and close one time
- D: Full lock

2.6 Anti-collision of top scan

2.6.1 Anti-collision(Open) (optex : OA-EDGE T)

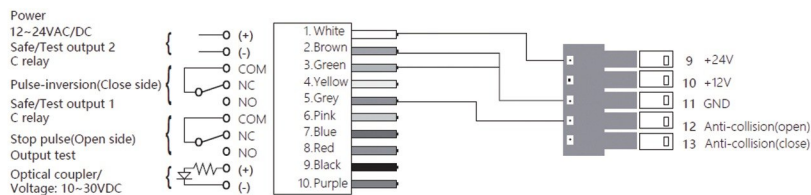

2.6.2 Anti-collision(Close)

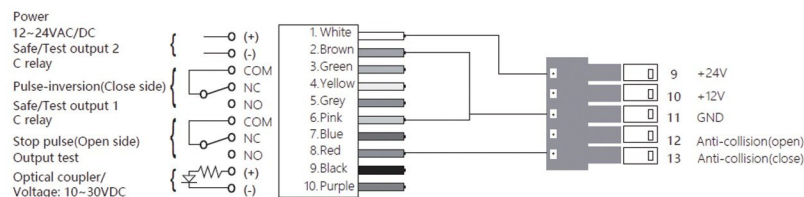

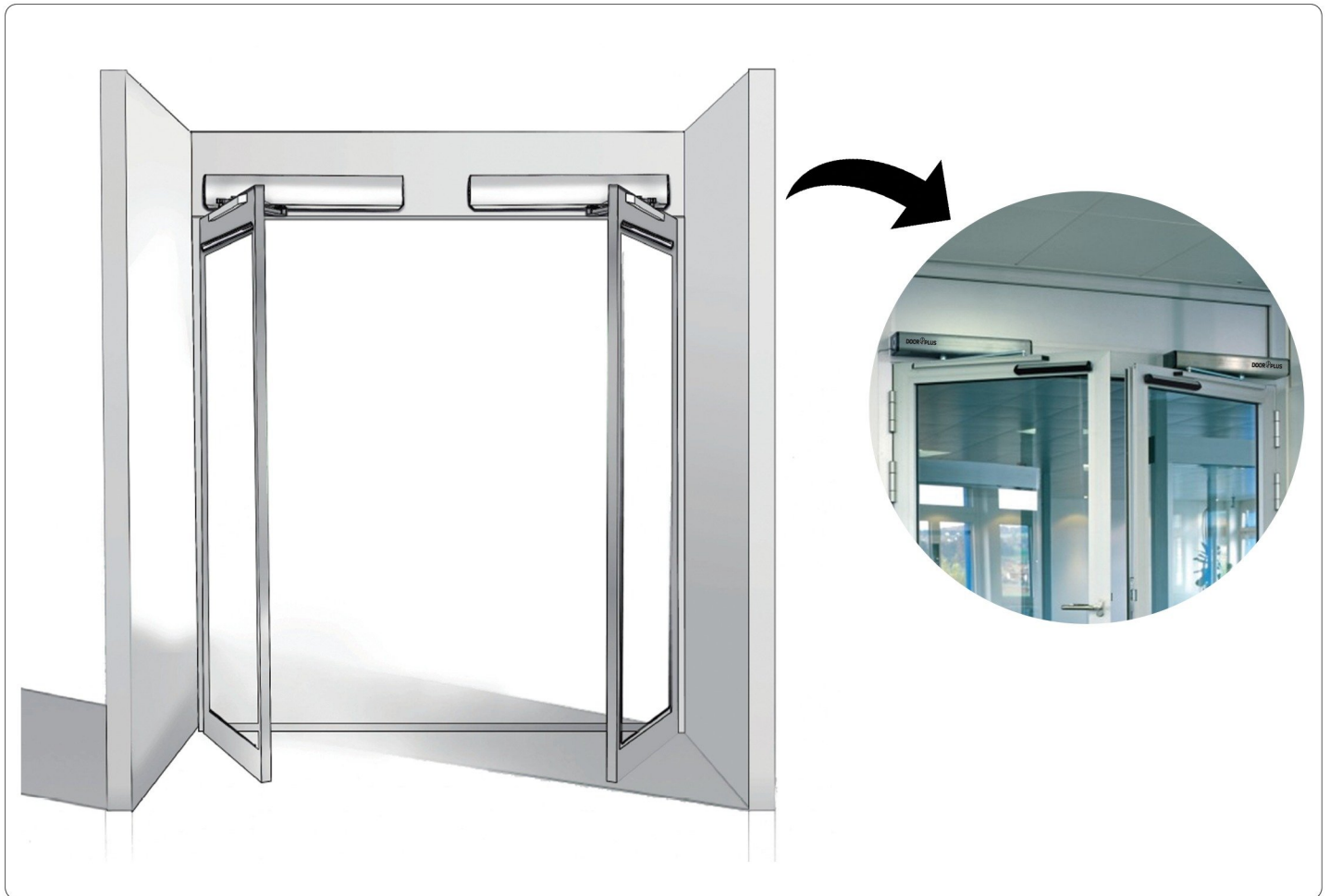

DP350 HEAVY DUTY | AUTOMATIC SWING DOOR

DP350: Classic Sophistication, EN16005 Certified Superiority

1 REVOLUTIONIZING SWING DOOR TECH

1.1 Short Description

The DP350 stands as a testament to innovation, aligning with the European EN16005 standard to guarantee adherence to safety protocols. Equipped with a sturdy brush motor, this door operator seamlessly incorporates a built-in spring design, ensuring uninterrupted functionality even in the absence of power. Offering the versatility of manual door opening and automatic closure through the integrated spring mechanism, the DP350 exhibits remarkable resistance to wind pressure. Tailored for outdoor doors, it excels in enduring strong winds while still providing manual operation, striking a harmonious balance between safety and convenience. With its robust features and compliance with industry standards, the DP350 proves to be a reliable choice for a wide array of outdoor door installations, ensuring smooth and secure access in every scenario.

1.2 Key Pros and Merits

The DP350 Swing Door Operator excels with a robust brush motor, built-in spring design, and wind-resistant features, ensuring secure and versatile access in compliance with EN16005 standards, ideal for outdoor use.

- EN16005 Standard Compliance
- Robust Brush Motor
- Built-in Spring Design
- Manual and Automatic Operation
- Wind-Resistant Features
- Ideal for Outdoor Doors
- Reliable in Strong Winds
- Safety and Convenience Blend
- Versatile Outdoor Installations
- Smooth and Secure Access

1.3 Areas of use

The DP350 Swing Door Operator caters to diverse applications, ensuring secure, efficient, and compliant access. Its features, including a robust brush motor and wind-resistant design, make it ideal for various settings, areas of usages are follows:

- Hospitals and Healthcare Facilities
- Office Buildings
- Hotels and Hospitality
- Residential Complexes
- Retail Stores and Showrooms
- Educational Institutions
- Public Transportation Hubs
- Government and Public Buildings
- Industrial Facilities
- Entertainment Venues



Automatic/Manual/Full open
3 modes switch



Spline shaft design
Strong connection



3 Types extension Meet
different installation space.



Built-in spring design
Work as door closer when no power.



LED display, Easy operation



Low energy mode, providing
disabled access solution.

2 PRODUCT

2.1 Product Description

The DP350 Swing Door Operator embodies a new era in door automation, adhering to the rigorous European EN16005 standards to guarantee not just compliance but excellence in operation. With a robust brush motor at its core, the DP350 ensures the fluid and efficient movement of doors, setting a standard for seamless access.

In moments of power outages, the built-in spring design steps in, serving as a reliable door closer, affirming continuous functionality. This dual-mode operation provides users the flexibility of manual door opening and the convenience of automatic closure facilitated by the integrated spring mechanism. Its adaptability extends to outdoor installations, showcasing exceptional resistance to wind pressure, making it a resilient choice for various weather conditions.

Beyond its technical prowess, the DP350 isn't just a swing door operator; it's a versatile solution designed to enhance entrances across diverse settings. Whether it's in commercial spaces, residential buildings, healthcare facilities, or educational institutions, the DP350 promises secure, adaptable access, making a lasting impression through its reliability and sophistication in every environment.

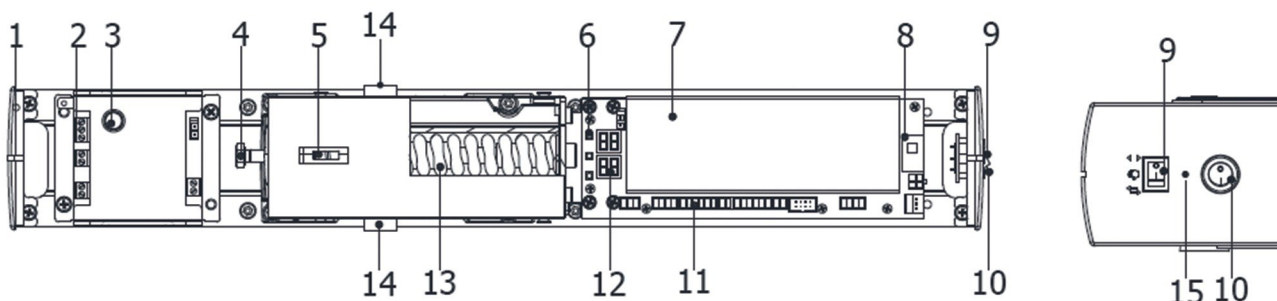

- 1. Side cover 2. Power input 3. Fuse 4. Spring force adjustment screw 5. Windows
- 6. Parameter adjustment button 7. Controller 8. Push / pull arm selection switch 9. Mode switch
- 10. Power switch 11. Wiring terminal 12. LED display 13. Mode switch 14. Motor output shaft
- 15. Power indicator

2.2 Pull/Push arm selection

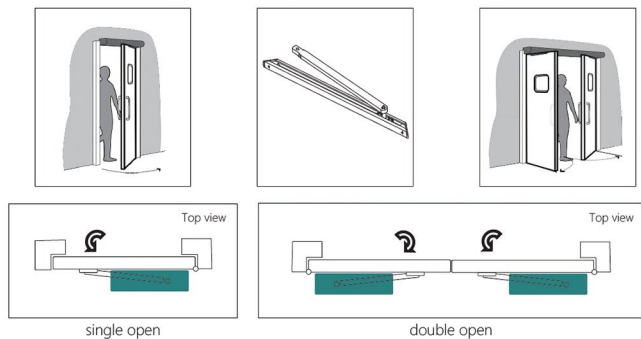

2.2.1 Pull arm

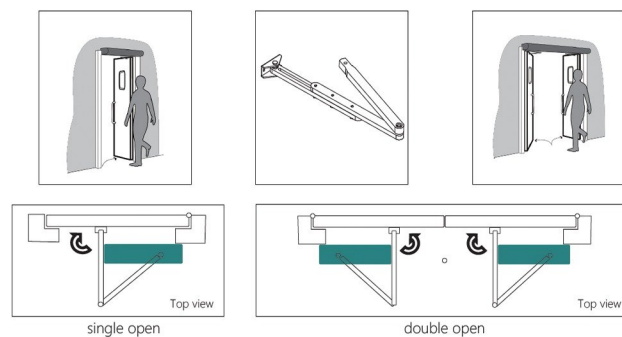

2.2.2 Push arm

2.3 Direction of operator installation

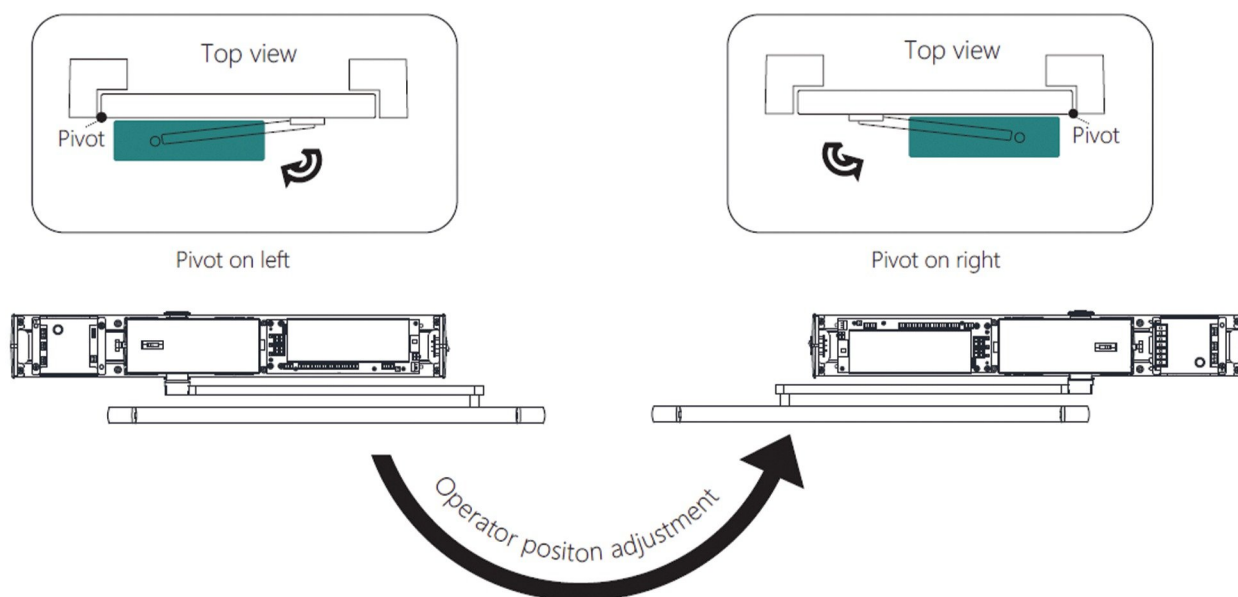

Factory default is left open. If it is Right open, you need to remove the motor, transformer and side cover by yourselves and rotate them by 180° and reassemble them.

2.4 Terminal specification

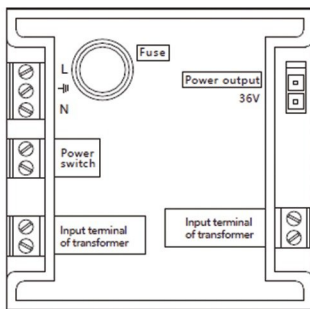
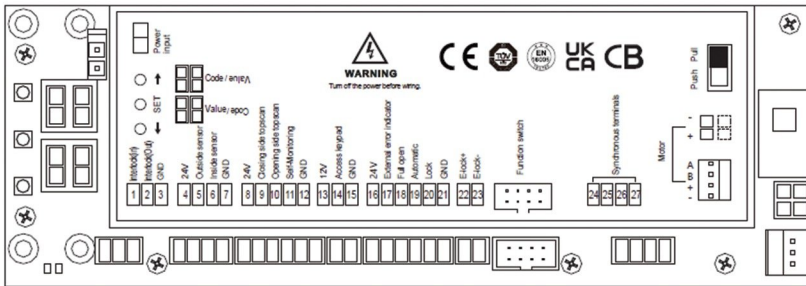

1	Interlock(in)
2	Interlock(Out)
3	GND
4	24V
5	Outside sensor
6	Inside sensor
7	GND
8	24V
9	Closing side topscan
10	Opening side topscan
11	Self-test signal
12	GND
13	12V
14	Card reader
15	GND

16	24V
17	Error feedback output
18	Full open
19	Automatic
20	Lock
21	GND
22	E-lock+
23	E-lock-
24	
25	Synchronous signal
26	
27	

2.5 Wiring diagram

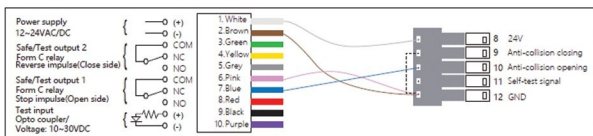

Note: When only connect top scan sensor on opening side have to short-circuit terminal 9 and 12, And Set Pn32 to 04



2.5.1 Opening side (OPTEX OA-EDGE T Master)

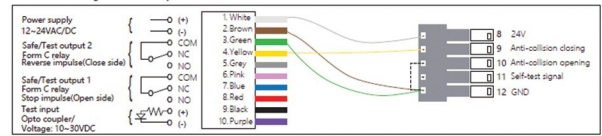

Note: When only connect top scan sensor on opening side have to short-circuit terminal 10 and 12, And Set Pn32 to 04

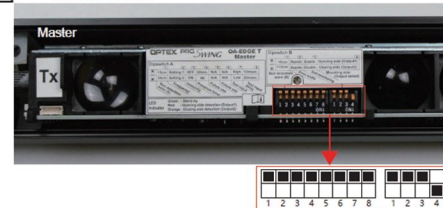

2.5.2 Closing side (optex : OA-EDGE T Master)

2.6 Microwave sensor

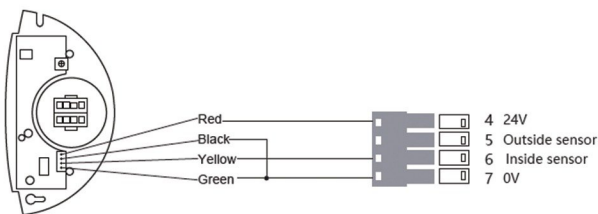

2.6.1 Inside sensor

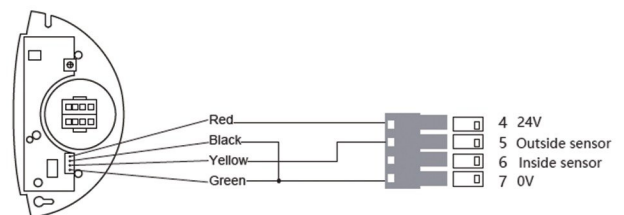

2.6.2 Outside sensor

2.7 Photocell

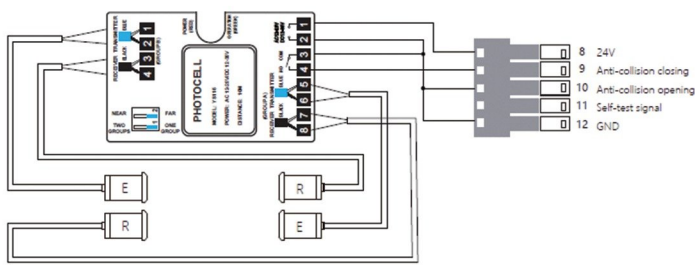

(Note: Photocell have to use the "NC" signal)

2.8 Footkick sensor

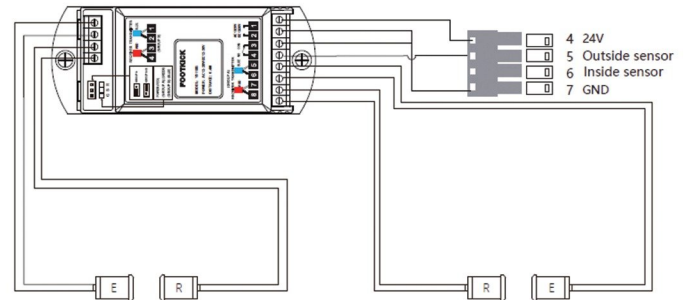

2.9 Product specifications

Product features	DP80 Extreme Drive	DP100 Slim drive
Height	83mm	98mm
Width	55mm	81mm
Length	555mm	475mm
Leaf weight - Max	100kg	150kg
Door width	1200mm	1200mm
Open speed	45/s	45/s
Close speed	45/s	45/s
Opening time	0-6s (adjustable)	3-7s /90°
Enclosure rating	IP21	IP21
Door opening angle	99°(max)	110° (max)
Temperature range	-20°C~ + 50°C	-20°C~ + 50°C
Input voltage	AC 100 V -240V 50-60Hz	AC 100V -240V
Output voltage	24V DC (± 10%)3A	24 V DC
Approvals	EN ISO13849-1:2015 EN60335-1:2012/A15:2021 EN60335-2-103:2015	EN ISO13849-1:2015 EN60335-1:2012/A15:2021 EN60335-2-103:2015
Certifications	CE passed ISO passed ISO 9001 quality certification 18 month warranty	CE passed ISO passed ISO 9001 quality certification 18 month warranty

2.9 Product specifications

Product features	DP200 Intensive drive	DP 350 Heavy duty
Height	115mm	90mm
Width	81mm	610mm
Length	518mm	128mm
Leaf weight - Max	200kg	350kg
Door width	1800mm	1400mm
Open speed	45/s	40/s
Close speed	45/s	30/s
Opening time	0-60s (adjustable)	3-c (adjustable)
Enclosure rating	IP21	IP21
Door opening angle	60° -115° (adjustable)	105° (max)
Temperature range	-20°C~ + 50°C	-20°C~ + 50°C
Input voltage	AC 100-240V input 220V AC	AC 200 V-240 V 50 -60Hz
Output voltage	24V DC	24V DC (± 10%)3A
Approvals	EN 16005:2012 EN ISO13849-1:2015 EN60335-1:2012/A15:2021 EN60335-2-103:2015 TUV certified	EN 16005:2012 EN ISO13849-1:2015 EN60335-1:2012/A15:2021 EN60335-2-103:2015 TUV certified
Certifications	CE passed ISO passed ISO 9001 quality certification 2 million passed trouble free test 24 month warranty	CE passed ISO passed ISO 9001 quality certification 2 million passed trouble free test Passed CB certification Passed the UKCA certification 24 month warranty

3.0 Conclusion

In conclusion, DoorPlus presents a lineup of cutting-edge products – DP80, DP100, DP200, and DP350. Compliant with safety standards, these solutions offer versatile, reliable, and sophisticated access control. From sleek design to robust features, DoorPlus products redefine entrances, setting new benchmarks for security and convenience.

Empowering Your Entry Experience

"DOOR PLUS AUTOMATIC SWING DOOR SYSTEMS"

DOOR PLUS

www.doorplusme.com

DOORPLUS GmbH , Städte und Gemeinden , 43219 olat Scholz

Tel +49(0) 7139- 213-694 | Fax +49(0) 7139- 213-594

E- Service.advise@doorplusme.com

GERMANY

